

Fairfax County

Typical Finished Basement Details

Based on the 2003 Virginia Uniform Statewide Building Code

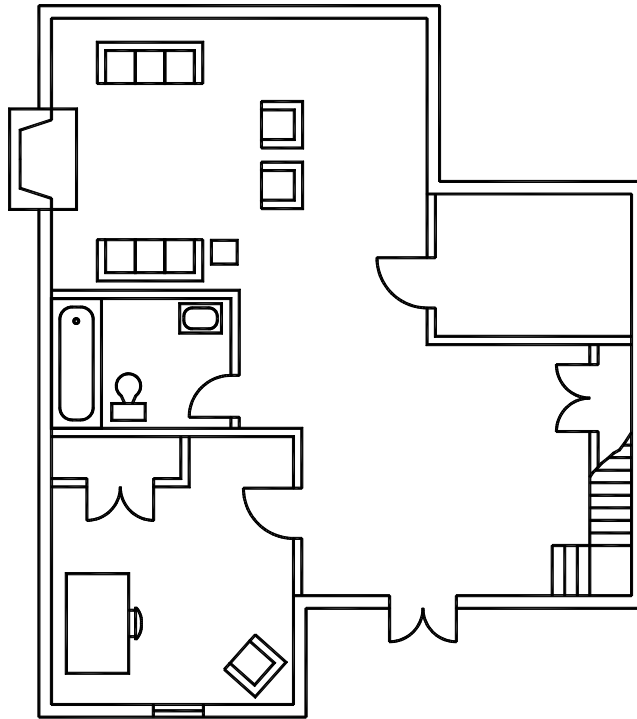

CONTENTS

General Building Requirements	2
Egress Requirements	2
Wall Construction	4
Floor/ceiling Construction	6
Mechanical Requirements	7
Plumbing Requirements	7
Electrical Requirements.....	8

Finished basements must be constructed in strict conformance with these details and the 2003 *International Residential Code* (IRC). For requirements, details and information not contained herein, you must consult the IRC. You may purchase an IRC from the Publications Center, 12000 Government Center Parkway, Suite 156, Fairfax, telephone 703-324-2974 or online at www.iccsafe.org. A copy of these details is required to be available on the job site and available to the inspector during the construction and inspection process.



Fairfax County
VIRGINIA

Typical Finished Basement Details
Based on the 2003 Virginia Uniform
Statewide Building Code

GENERAL BUILDING REQUIREMENTS

ROOM SIZES: Habitable rooms, excluding closets, hallways, laundries, storage spaces and bathrooms, shall have an area of not less than 70 sf and shall not be less than 7'-0" in any direction.

HALLWAYS: Hallways shall not be less than 36" in width.

CEILING HEIGHTS: Basement ceiling heights shall not be less than 7'-0". Structural members spaced at 4'-0" or more may project a maximum of 6" below the required ceiling height.

BATHROOM VENTILATION: Bathrooms shall be equipped with a mechanical ventilation system vented directly to the outside. Mechanical ventilation is not required when a window is provided with a minimum opening of 1.5 sf.

STAIR PROTECTION: Enclosed accessible space under stairs shall have walls and ceilings protected with 1/2" drywall on the enclosed side.

SMOKE ALARMS:

- **Basement:** smoke alarms (smoke detectors) shall be installed in the basement and in each basement bedroom. New smoke alarms shall be interconnected so that when one is activated, all will sound. Smoke alarms must be hardwired with a battery backup.
- **In the remainder of the house:** if smoke alarms are not located on each floor, in each bedroom and in the vicinity of bedrooms, then one must be installed in such locations. Alarms need not be interconnect and may be battery powered only.

STAIRWAY ILLUMINATION: Fairfax County recommends that all basement stairs be provided with a means to light the treads and landings of stairs. There should be a switch to the light at the top and bottom of the stairs.

BASEMENT WALL INSULATION: Fairfax County recommends installing a minimum of R-11 battened insulation (with the vapor barrier on the warm side of the wall) for the full height and length of the basement wall.

EMERGENCY EGRESS REQUIREMENTS

WHERE REQUIRED: Emergency egress is required for all finished basements regardless of when the house was originally constructed. Emergency egress is also required in all basement bedrooms. However, basements with bedrooms are only required to have emergency egress in the bedrooms.

If your basement does not currently have one of the emergency egress options below, then you must provide one. **Cutting openings in existing basement walls is outside the scope of these details. Therefore, a plan submission is required for the new openings only.** All other conditions of the finished basement may be taken from these details.

EMERGENCY EGRESS OPTIONS:

- Escape window opening directly to the outside (walk-out basement condition).
- Escape window opening into a window well or areaway.
- Door opening directly to outside (walk-out basement condition).
- Door opening to bulkhead enclosure (Bilco or similar type door).

REQUIREMENTS:

- All doors and windows utilized as emergency egress must be operable from the inside without the need of a key or tool.
- The opening used for emergency egress must be a minimum of 5.0 sf.
- Windows must have a sill 44" or less above the finished floor.
- See FIGURE 1 for more opening requirements.



Fairfax County
VIRGINIA

Typical Finished Basement Details
Based on the 2003 Virginia Uniform
Statewide Building Code

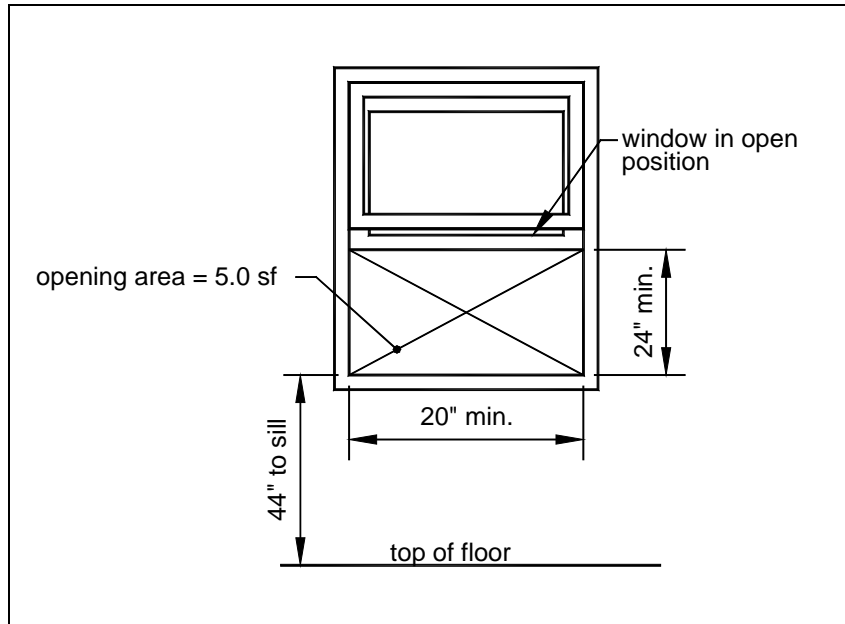

FIGURE 1: WINDOW EGRESS REQUIREMENTS

WINDOW WELL REQUIREMENTS: When grade conditions require the sill of the egress windows to be below the outside grade elevation, then a window well must be constructed. The required horizontal area of a window well is a minimum of 9 sf which is measured when the window is in the open position (this is important with the window is a crank-out type). When the window well is greater than 30" deep and adjacent to a walkway, a guard or cover must be provided. Covers must be openable without a key or tool. For typical guard details, see the *Fairfax County Typical Deck Details*. See FIGURE 2.

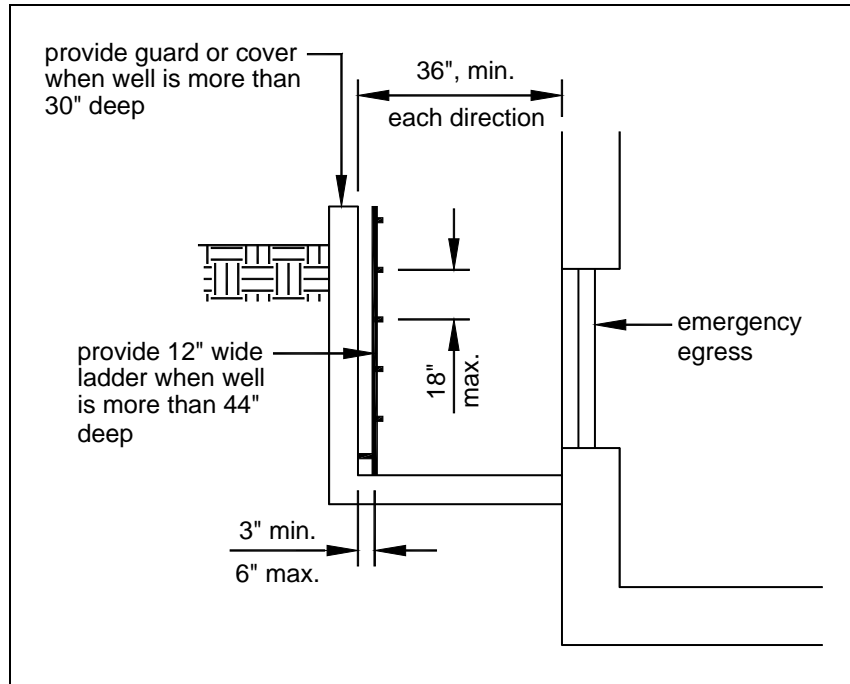

FIGURE 2: TYPICAL WINDOW WELL REQUIREMENTS

WINDOW WELL CONSTRUCTION: Window wells may be constructed using the *Fairfax County Typical Retaining Wall Details*. Approved prefabricated wells may be substituted.



Fairfax County
VIRGINIA

Typical Finished Basement Details
Based on the 2003 Virginia Uniform
Statewide Building Code

LADDER REQUIREMENTS: When a window well is greater than 44" deep, permanently attached ladders or steps must be provided. Ladders must be a minimum of 12" wide and rungs must be spaced a maximum of 18" on center. Ladders must be a minimum of 3" away from the wall or well and may project into the required window well area no more than 6". If the ladder projects more than 6" into the required area, the size of the window well must be increased to maintain the required area. See FIGURE 2.

REQUIREMENTS FOR WALL CONSTRUCTION

STUDS: Studs may be utility grade or better. Stud shall be spaced be per TABLE 1. Walls shall have a single pressure treated bottom plate and can have a single or double top plate.

TABLE 1: STUD SPACING

Wall Finish Material	Stud spacing, inches on center
Drywall	16 or 24
Wood veneer, hardwood paneling	16

ATTACHMENT REQUIREMENTS: Wall construction shall be fastened in accordance with TABLE 2.

TABLE 2: FASTENING SCHEDULE

Connection	Nailing method
Top plate to stud	end nail, 16d @ 24"o.c.
Stud to bottom plate	toe nail, 2-16d
Bottom plate to floor	face nail, 6d (concrete nail) @ 16"o.c.

DRILLING AND NOTCHING STUDS: Studs in non-load bearing walls may be notched up to 40% of the stud width. Studs may be drilled up to a diameter equal to 40% of the stud width provided the edge of the hole is no closer than 5/8" to the edge of the stud, and the hole is not located in the same section as a cut or notch. See FIGURE 3.

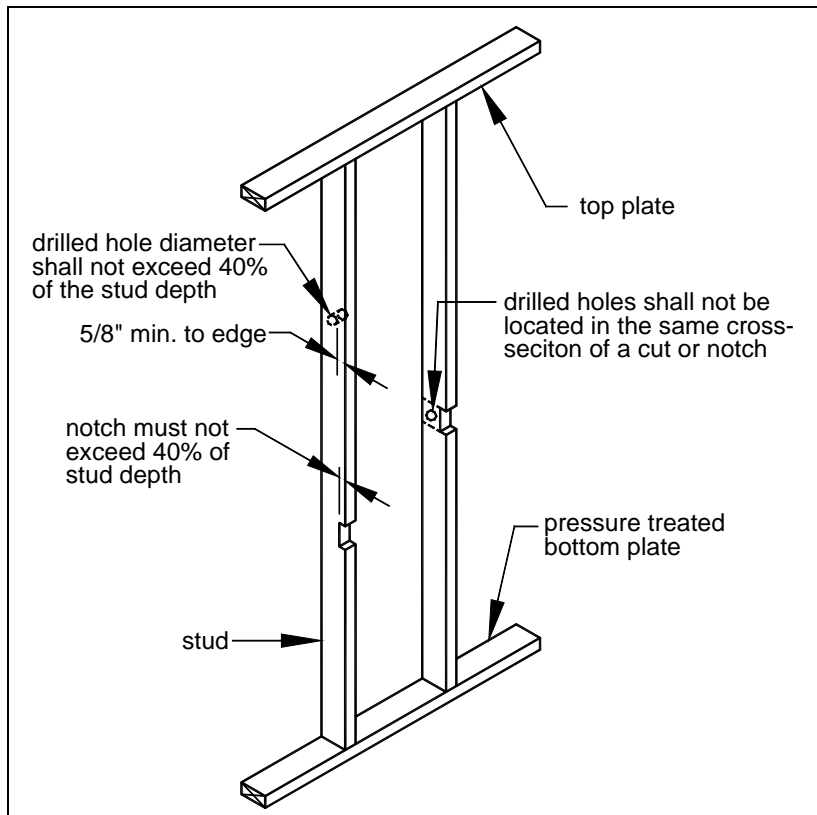

FIGURE 3: DRILLING & NOTCHING STUDS



**Fairfax County
VIRGINIA**

Typical Finished Basement Details
Based on the 2003 Virginia Uniform
Statewide Building Code

HEADERS: A single flat 2x4 member may be used as a header in interior nonbearing walls for openings up to 8 feet in width if the wall above is not more than 24 inches. If the opening does not meet the above conditions, the header size shall be per TABLE 3.

TABLE 3: HEADER SIZE

Header Size	Span length, feet
(2)2x4	4
(2)2x6	6
(2)2x8	10
(2)2x10	12
(2)2x12	16

FIRE BLOCKING: Fire blocking shall be provided to cut off all concealed draft openings and to form an effective fire barrier between stories. See FIGURE 4- FIGURE 6. Fire blocking shall be provided in the following locations.

- In concealed spaces of stud walls and partitions, including furred spaces, at the ceiling and floor level and at 10'-0" intervals;
- At all interconnections between concealed vertical and horizontal spaces such as occur at soffits, drop ceilings, cove ceilings, etc;
- In concealed spaces between stair stringers at the top and bottom of the run.
- At gaps 1" or less and at openings around vents, pipes, and ducts at the ceiling and floor level; batts or blankets of mineral wool or fiberglass must be used.

FIRE BLOCKING MATERIAL: Fire blocking shall consist of one of the materials listed below. The integrity of all fire blocking must be maintained.

- 2x lumber (2x4, 2x6, etc.).
- Two thicknesses of 1x lumber (1x4, 1x6, etc.) with staggered joints.
- One thickness of $\frac{23}{32}$ " of plywood or OSB with joints backed with the same material.
- One thickness of $\frac{3}{4}$ " particleboard with joints backed same material.
- $\frac{1}{2}$ " gypsum board
- 3" cement based millboard.
- Batts or blankets of mineral wool or fiberglass.

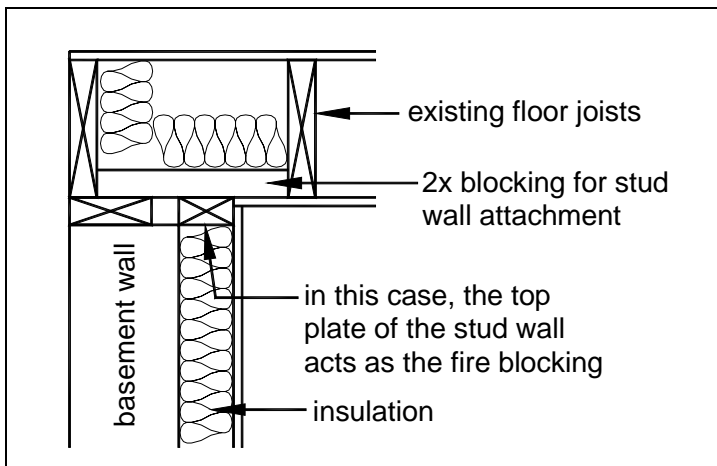

FIGURE 4: TYPICAL FIRE BLOCKING DETAIL



Fairfax County
VIRGINIA

Typical Finished Basement Details
Based on the 2003 Virginia Uniform
Statewide Building Code

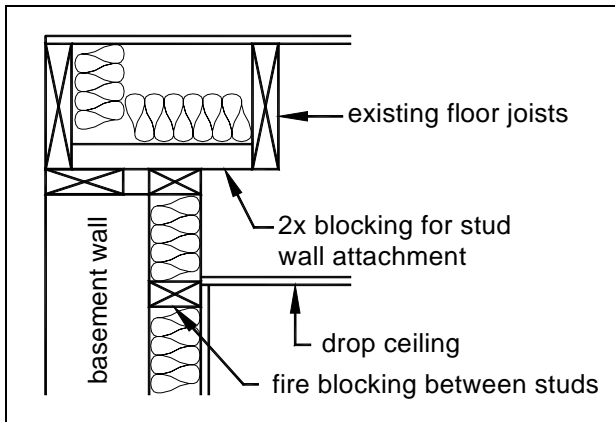

FIGURE 5: FIRE BLOCKING AT DROP CEILING

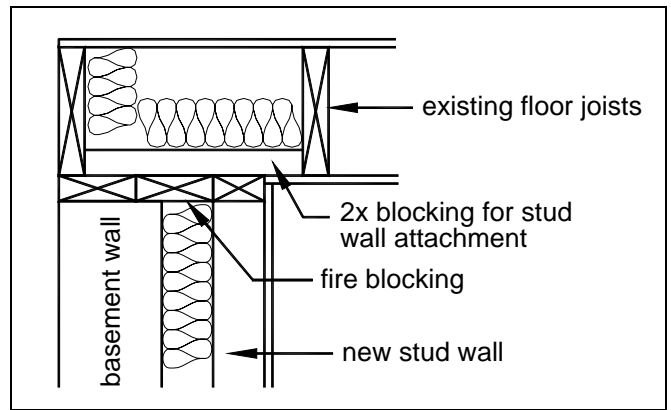

FIGURE 6: FIRE BLOCKING AT OFFSET STUD WALL

INTERIOR COVERING: Wall and ceiling material must meet the requirements below.

- Materials must have a flame spread classification no greater than 200 and a smoke density classification no greater than 450. This does not apply to trim, molding, handrails and doors.
- Water resistant drywall must be installed on walls of bathtub and shower spaces and finished with a non-absorbent surface.
- Wood veneer or hardboard paneling less than 1/4" shall not be permitted.

REQUIREMENTS FOR FLOOR/CEILING CONSTRUCTION

DRILLING AND NOTCHING JOISTS: Notches in the top or bottom of joists must not exceed one-sixth the of the joists' depth and cannot be located in the middle third of the span. Cantilevered (overhanging) joists cannot be notched. Holes drilled in joists shall not be within 2" of the top or bottom of joists, and their diameter shall not exceed one-third the depth of the joist. See FIGURE 7. Drilling and notching of manufactured wood products (TJI, LVL) shall be per manufacturers' instructions.

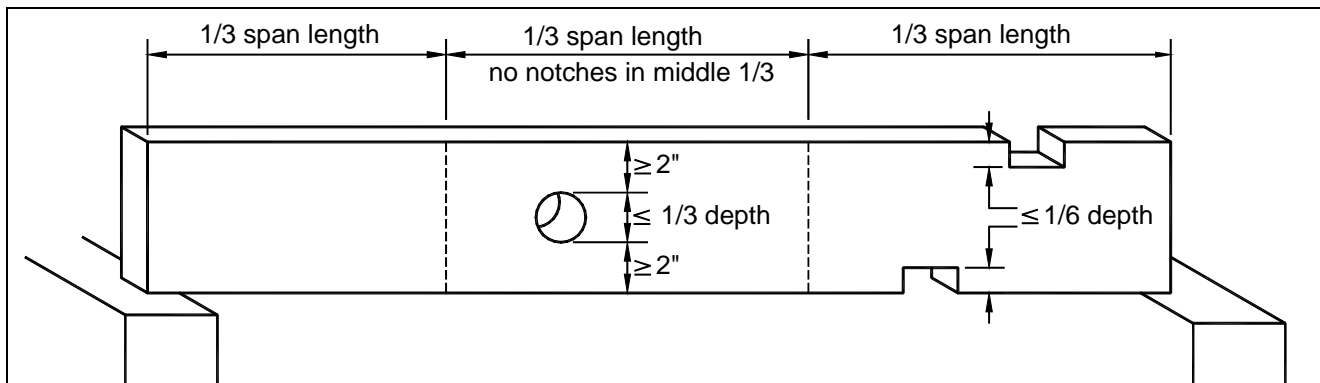

FIGURE 7: DRILLING AND NOTCHING OF JOISTS

DRAFTSTOPPING: When the ceiling of the finished basement is not attached directly to the underside of the floor joists above or when the floor joists are comprised of open web trusses, draftstopping must be provided. Sufficient draftstopping must be installed such that the area of the concealed space does not exceed 1,000 sf and is divided into approximately equal areas. Draftstopping shall be installed parallel to the floor framing members. See FIGURE 8 and FIGURE 9

DRAFTSTOPPING MATERIAL: Draftstopping shall consist of one of the materials listed below. The integrity of all draftstopping must be maintained

- 1/2" gypsum board
- 3/8" wood plywood or OSB
- 3/8" particleboard, type 2-M-W.



**Fairfax County
VIRGINIA**

Typical Finished Basement Details
Based on the 2003 Virginia Uniform
Statewide Building Code

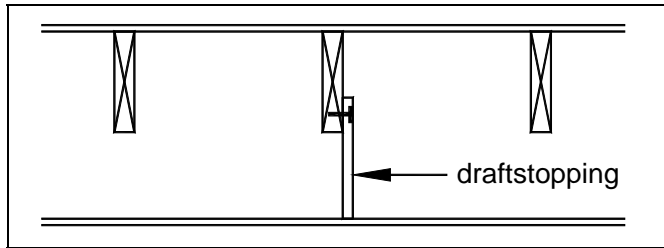

FIGURE 8: DRAFTSTOPPING AT DROP CEILING

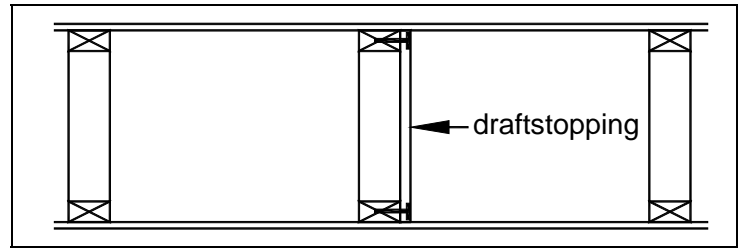

FIGURE 9: DRAFTSTOPPING AT OPEN WEB TRUSSES

MECHANICAL REQUIREMENTS

APPLIANCE ACCESS: Furnaces, hot water heaters and other appliances must be accessible without removing permanent construction and shall meet the following minimum criteria.

- 30"x30" clear floor space at front/control side.
- 6" clearance all other sides and top.
- Doors to furnace rooms shall be 24" minimum and be of sufficient size to remove the largest appliance.

COMBUSTION AIR: Furnace rooms with fuel-burning appliances must be provided with two permanent openings to adjacent spaces: one within 12" of the top and one within 12" from the bottom of the adjoining wall. Each opening must have a minimum free area equal to 1 in² per 1,000 Btu/h input rating of all appliances in the furnace room, but not less than 100 in². The openings are not required if a louvered door is provided or the furnace room area is greater than 50 ft³ per 1,000 Btu/h input rating of all appliances installed in the room.

PLUMBING REQUIREMENTS

SHOWERS: Showers and shower compartments must meet the following requirements.

- Shower compartments must have a minimum total area of 900 in² and a minimum dimension of 30" in any direction.
- Hinged shower doors must open outward.
- All glass which encloses a shower must be safety glazed.
- Shower control valves must be scald resistant (in accordance with ASSE/ANSI 1016) with a hot water limit of 120° F.

FIXTURE CLEARANCES: Toilets, sinks, and showers shall have the minimum clearances listed below.

- 21" in front of sinks and toilets.
- 24" in front of shower stall opening.
- 4" between two adjacent sinks.
- 4" between a sink and a toilet.
- 4" between a sink and a wall.
- 2" between a sink and a bathtub.
- 15" clearance from a toilet's centerline to an adjacent fixture or wall on each side.

DRAIN SIZE: Fixture drain size must meet the dimensions noted below. All drains must be equipped with a strainer and stopper.

TABLE 4: MINIMUM DRAIN SIZE

Fixture	Diameter
Bathroom sink	1 ¹ / ₄ "
Bathtubs	1 ¹ / ₂ "
Sinks (other than bathroom)	1 ¹ / ₂ "
Laundry tubs	1 ¹ / ₂ "



Fairfax County
VIRGINIA

Typical Finished Basement Details
Based on the 2003 Virginia Uniform
Statewide Building Code

CLOTHES WASHER DISCHARGE: The discharge of a clothes washer must be through and air break as shown in FIGURE 10.

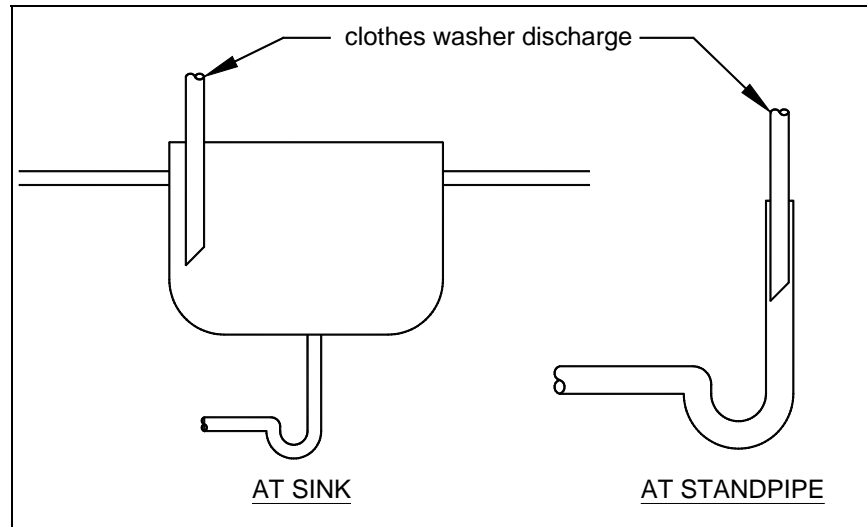

FIGURE 10: AIR BREAK AT CLOTHES WASHER DISCHARGE

ELECTRICAL REQUIREMENTS

PANELBOARD (CIRCUIT BREAKER BOX): Panelboards must meet the requirements listed below.

- A workspace 30" wide and 36" deep from floor to the ceiling with a minimum height of 6'-6" shall be provided in front of the panelboards.
- Panelboard workspace must not be used for storage at any time.
- Panelboards must not be located in clothes closets or bathrooms.
- Provide a light for the panelboard workspace.

BRANCH CIRCUITS: Branch circuits must meet the requirements listed below. See TABLE 5 for more information.

- Use a 15 to 20 ampere rated branch circuit for general use purposes such as lighting and outlets.
- One "plugged-in" electrical device shall not exceed 80% of the circuit rating.
- Hardwired appliances or equipment may be included in a general use circuit provided its rating does not exceed 50% of the circuit rating.
- A dedicated 20 ampere minimum branch circuit must be provided to serve laundry room outlets only.
- A dedicated 20 ampere branch circuit must be provided to serve a single bathroom.
- Circuits which serve bedroom outlets must have circuit breakers equipped as arc-fault circuit interrupters.

TABLE 5: BRANCH CIRCUIT REQUIREMENTS

	Circuit Rating		
	15 amp	20 amp	30 amp
Min. conductor size	14	12	10
Max. breaker size, ampere	15	20	30
Outlets rating, amperes	15 max.	15 or 20	30
Maximum load, amperes	15	20	30



Fairfax County
VIRGINIA

Typical Finished Basement Details
Based on the 2003 Virginia Uniform
Statewide Building Code

OUTLETS (RECEPTACLES): Outlets must meet the requirements listed below.

- Outlets shall be placed so that no location along the floor/wall line is more than 6'-0" from an outlet. See FIGURE 11
- The minimum wall length which requires an outlet is 2'-0".
- Kneewalls, built-in bars, and other fixed room dividers must be included in wall length for outlet spacing.
- Hallways more than 10'-0" long must have a minimum of one outlet.
- Outlets installed for specific appliances must be within 6'-0" of the appliance location.
- Bathrooms must have at least one outlet located on a wall adjacent and within 36" of the bathroom sink. All bathroom outlets must have ground fault circuit interrupter (GFCI) protection.
- At least one outlet must be provided to serve laundry appliances.
- Each unfinished portion of the basement is required to have at least one outlet.
- An outlet must be provided within 25'-0" of heating and air-conditioning appliances and equipment.
- All outlets shall be 125 volt, single phase, 15 and 20 ampere.

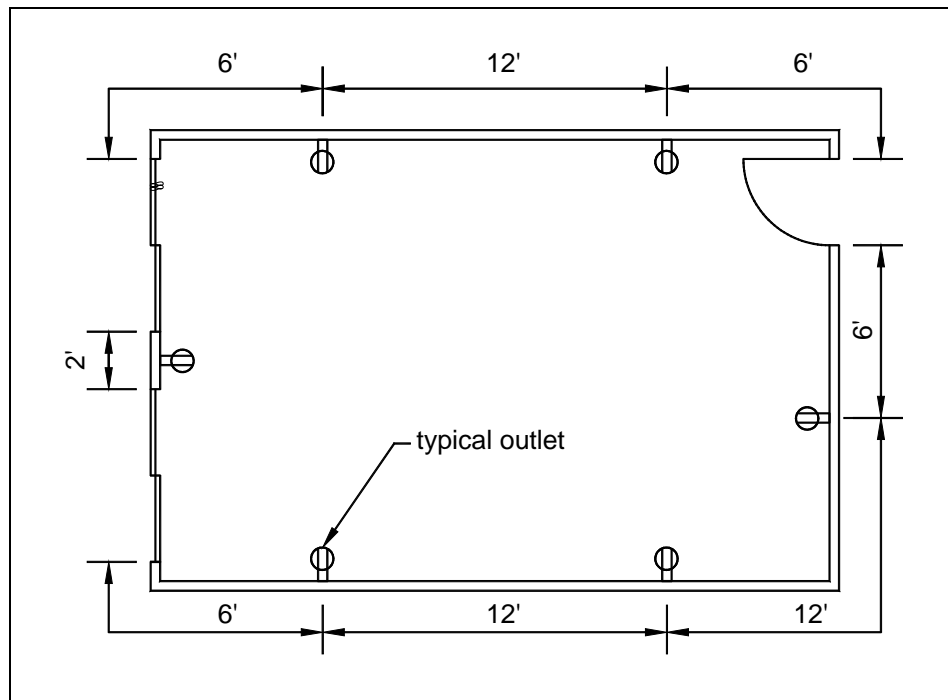

FIGURE 11: TYPICAL OUTLET DISTRIBUTION

LIGHTING REQUIREMENTS: Lights must meet the requirements listed below.

- At least one switch controlled light must be provided in each room and hallway. A switch controlled outlet may be substituted in all rooms except bathrooms and hallways.
- At least one switch controlled or pull chain light must be provided in each storage area and at or near heating and air-conditioning appliances and equipment.
- Lighting fixtures must not be installed within 3'-0" horizontally and 8'-0" vertically of a bathtub rim or shower stall threshold. A light fixture may be installed above a shower area if it is constructed so that water cannot enter or accumulate in wiring areas and the lighting fixture is marked "suitable for wet locations."
- Light fixtures must be installed so that combustible materials are not subject to temperatures greater than 90° F.



Fairfax County
VIRGINIA

Typical Finished Basement Details
Based on the 2003 Virginia Uniform
Statewide Building Code

LIGHT FIXTURES IN CLOSETS: The types of fixtures installed in clothes closets shall be limited to surface mounted or recessed incandescent fixtures with completely enclosed lamps, and surface mounted or recessed fluorescent fixtures. Incandescent fixtures with open or partially enclosed lamps and pendant fixtures or lamp holders are prohibited. See TABLE 6 for clearance requirements.

TABLE 6: CLOSET LIGHT FIXTURE CLEARANCES

Fixture Type	Bulb Type	
	Fluorescent	Incandescent*
Surface mounted	6	12
Recessed	6	6

*Bulb must be within a completely enclosed lamp.

Fairfax County is committed to a policy of nondiscrimination in all county programs, services and activities and will provide this document in alternative formats and in different languages upon request. Please call 703-324-5033, TTY 711 or write Department of Public Works and Environmental Services, Suite 659, 12055 Government Center Parkway, Fairfax, VA 22035-5506. Please allow at least seven working days for preparation of material.



Fairfax County
VIRGINIA

Typical Finished Basement Details
Based on the 2003 Virginia Uniform
Statewide Building Code